

CP GLASS CLEANER

THE MOST EFFICIENT AUTOMATED GLASS CLEAN-UP SYSTEM AVAILABLE

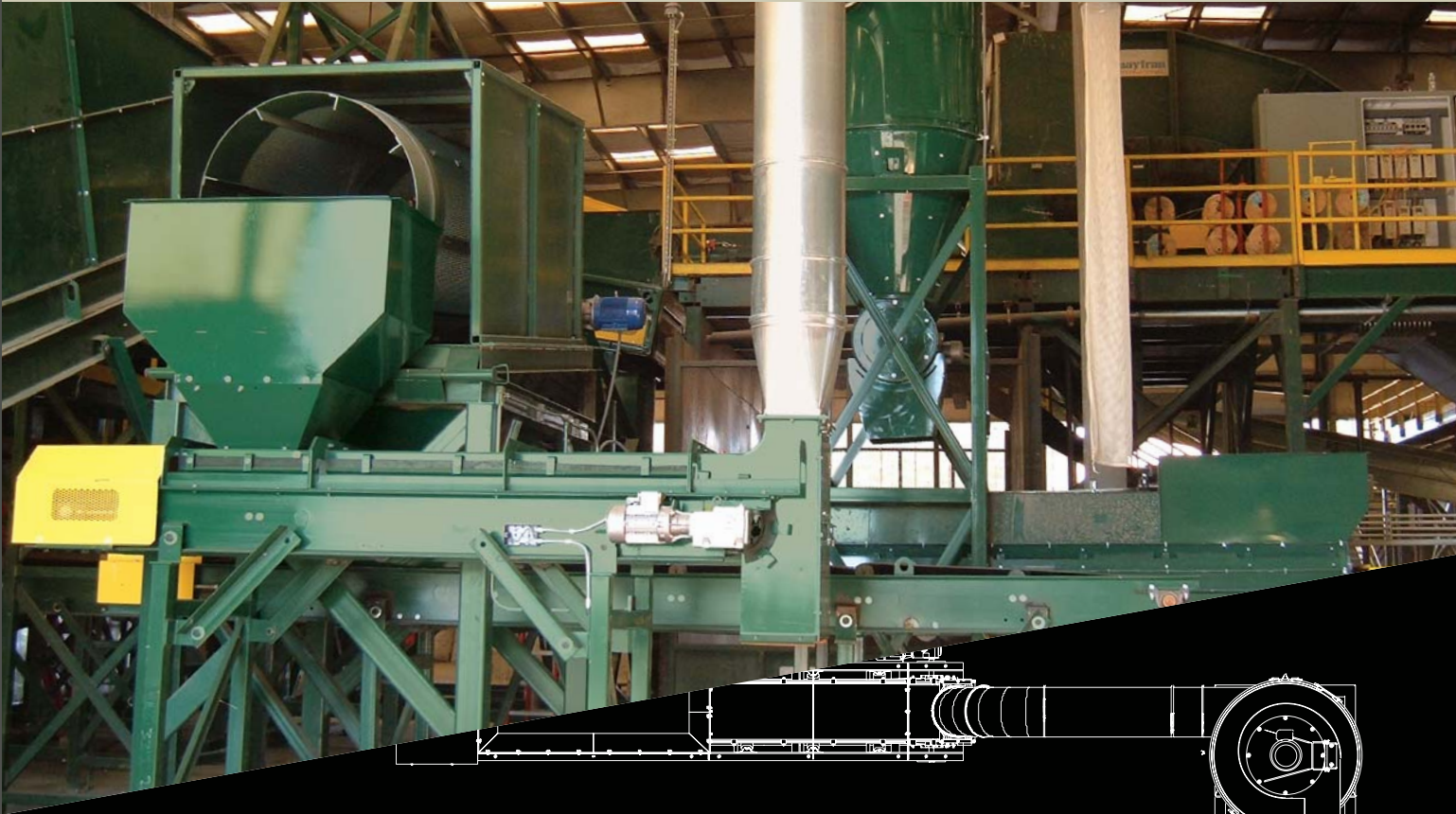

IMPROVE END-PRODUCT MARKETABILITY WITH THE BEST GLASS CLEANER IN THE INDUSTRY.

Utilizing state-of-the-art automation technology, CP Manufacturing brings glass cleaning to new levels of efficiency—and profitability—for your operation. The new CP Glass Cleaner features a unique vacuum system that separates fiber and other light debris from glass with the best field-proven results in the industry. Whatever the size of your MRF, you will see an immediate return on your investment—in terms of lower residue and higher end-product marketability.

DESIGNED FOR EASY RETROFIT.

CP's glass sorting system can be easily integrated into existing facilities. Install a CP Glass Cleaner, and you can be certain of a custom fit, prompt delivery, fast installation and rapid response to any questions or concerns.

CP MANUFACTURING: THE WORLD'S LEADER IN SEPARATION TECHNOLOGY.

All CP equipment is designed, built and field-proven 100% in our own plants. From start to finish, from conception to completion, no company does more to provide cutting-edge solutions for MRFs. Whether you process 100 tons a day or 1000, you can profit from the innovation, experience and dependability of CP Manufacturing.

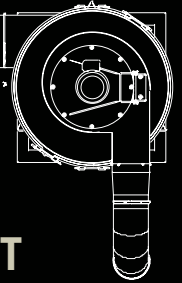

MATERIAL RECOVERY FACILITIES

CP GLASS CLEANER

THE HIGHEST QUALITY END-PRODUCT—AUTOMATICALLY

FINALLY—LOW MAINTENANCE, HIGH THROUGH-PUT GLASS SORTING.

Whether integrated into your Material Recovery Facility or used as a stand-alone unit, the CP Glass Cleaner will process up to 5 tons per hour of mixed and broken glass. Material is fed into an integrated hopper. Light material is separated by vacuum from heavy material and broken glass, and discharged by an extraction blower through a rotary valve at the base of the cyclone. Heavier glass drops into a horizontal outfeed conveyor for a final sort. Optional screening is available for infeed or outflow material.

FEATURES AND BENEFITS

- :: Provides more efficient separation of light materials from glass.
- :: Processes up to 5 tons per hour of broken glass.
- :: Eliminates light contaminants to maximize the quality of your end product.
- :: Increases marketability of your end product.
- :: Lowest maintenance costs in the industry.
- :: Utilizes a fully adjustable vacuum system for accurate and efficient separation.
- :: Variable speed drive to accommodate your processing needs.
- :: Incorporates urethane wear liners on all wear components (cyclone, barrel, rotary valve, etc.) increasing durability and extending equipment life.
- :: Designed and engineered for fast, easy retrofit.

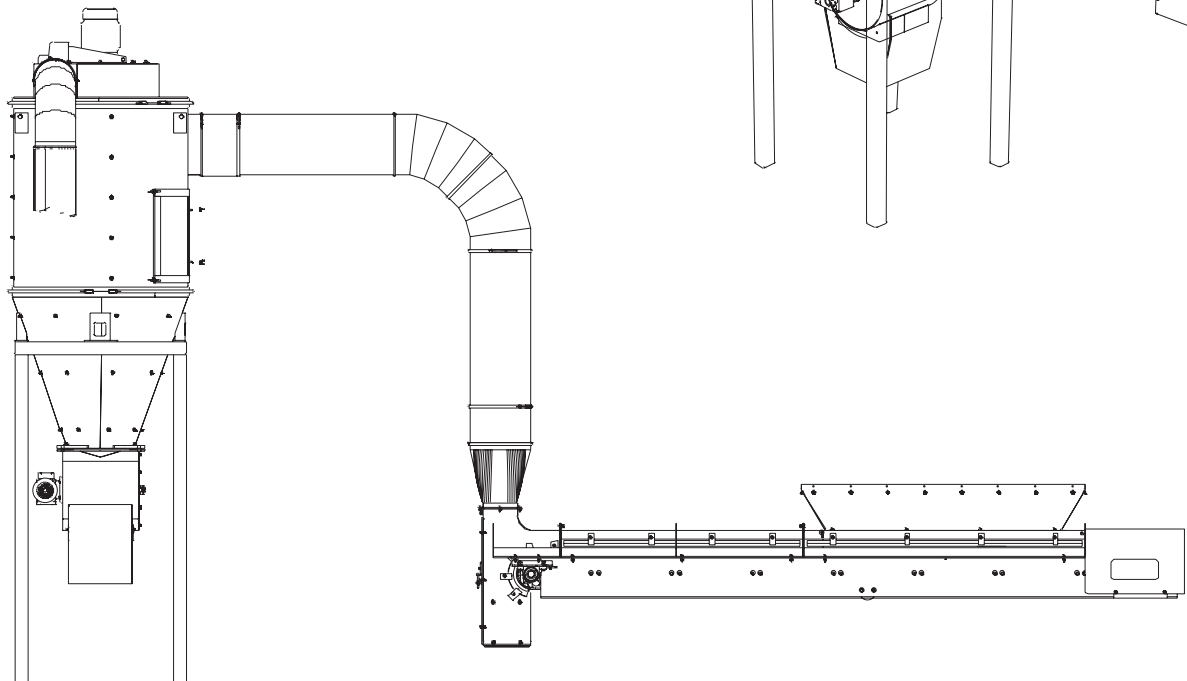
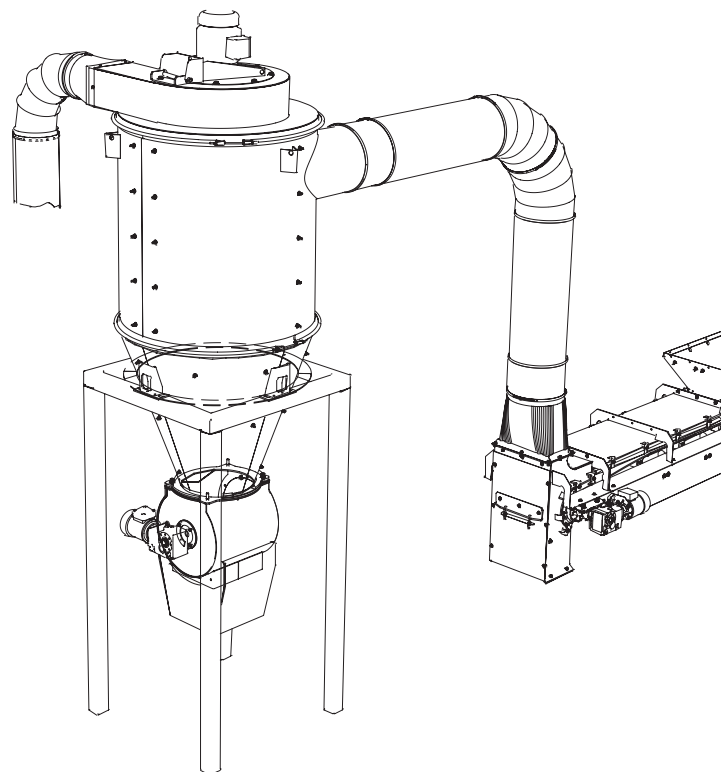

CP Manufacturing, Inc. ■ A Division of the CP Group of Companies ■ 1300 Wilson Avenue, National City, CA 91950, USA
(t) +1.619.477.3175 ■ (f) +1.619.477.2215 ■ (e) sales@cpmfg.com ■ (w) www.cpmfg.com

